

MILITARY AVIATION £21.99 / \$32.95

VICKERS WELLINGTON

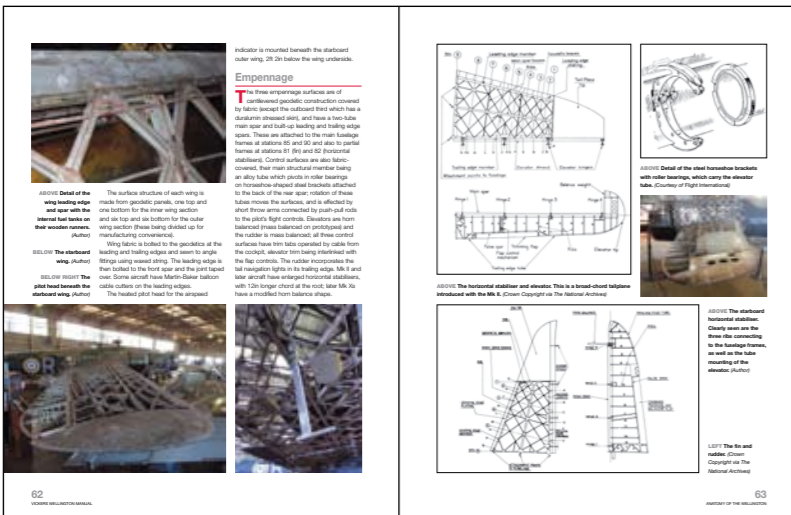

1936 to 1953 (all marks and models)



The twin-engined Vickers-Armstrongs Wellington was one of the outstanding RAF combat aircraft of the Second World War, seeing use with every RAF command and in almost every theatre of operations. It was widely considered to have been the best bomber to have seen service with Bomber Command in the early war period, as well as being a capable maritime patrol aircraft and submarine hunter with Coastal Command.

Designed in the thirties by Rex Pierson and Barnes Wallis, the Wellington used one of the new technologies of the age in its construction – geodetics. The unusual structure saw the Wellington dubbed the 'basket-weave bomber' by the press, and the 'cloth bomber' by the sceptical Americans. Yet, despite its strange utilisation of a modern structure with a traditional fabric covering, it was resilient in combat and simple to mass-produce, becoming the most numerous multi-engine aircraft ever built in Great Britain.

The centrepiece of this manual is Wellington Mk IA N2980, 'R for Robert', one of only two surviving examples of the Wellington anywhere in the world. Recovered from Loch Ness in 1985, where it had ditched 45 years earlier, 'R for Robert' has been painstakingly restored to display condition by the Brooklands Museum at Weybridge in Surrey.

Author Iain Murray gives a series of fascinating insights into the design, construction and operation of this historic aircraft with the help of many rarely seen photographs and technical illustrations.

Dr Iain Murray is a lecturer at the University of Dundee. He is the author of *Bouncing Bomb Man: The Science of Sir Barnes Wallis* (Haynes, 2009) and the *Dam Busters Manual* (Haynes, 2011). He lives in Dundee.

VICKERS WELLINGTON 1936 TO 1953 (ALL MARKS AND MODELS)

VICKERS WELLINGTON



1936 to 1953 (all marks and models)

Owners' Workshop Manual

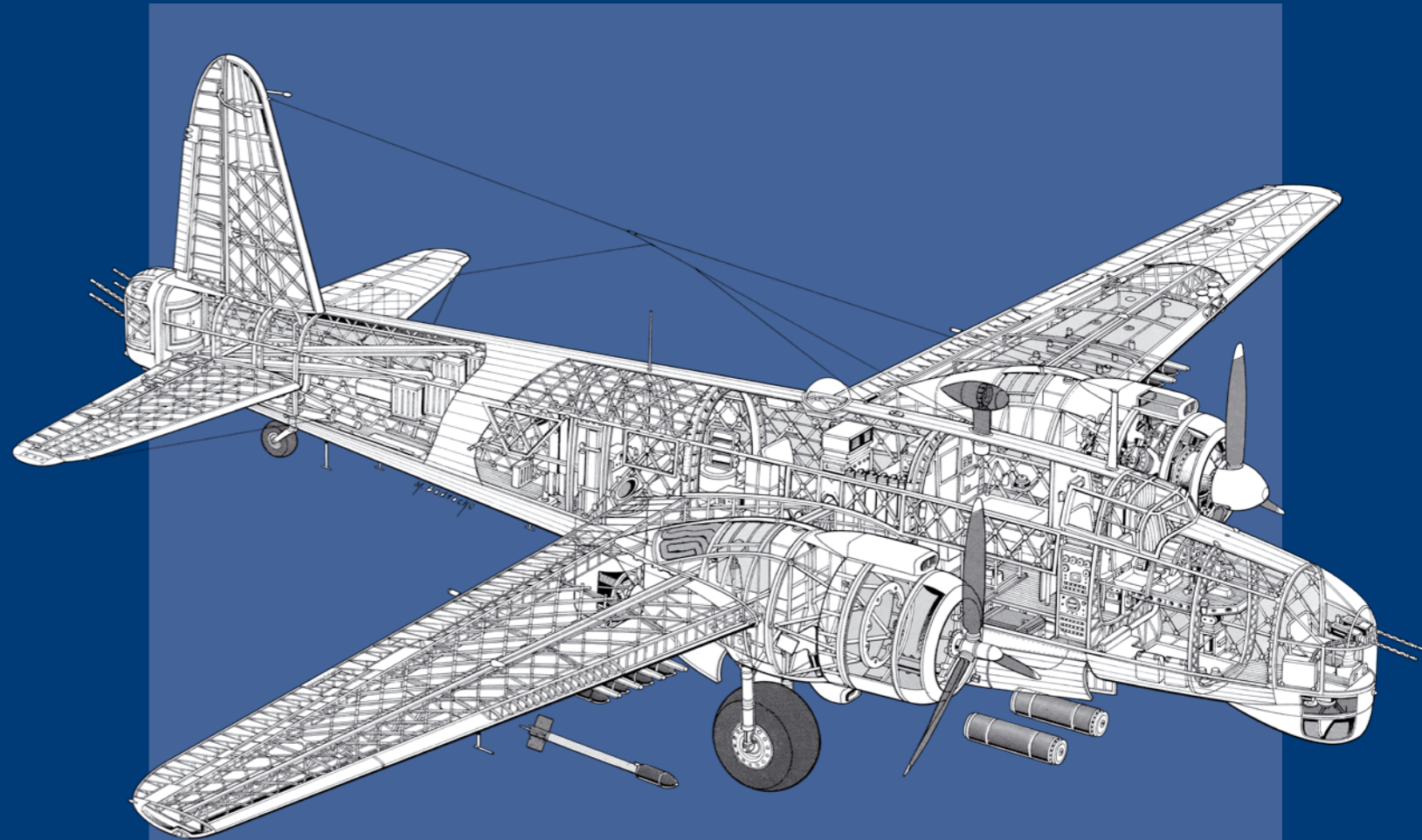

An insight into the history, development, production and role of the Second World War RAF bomber aircraft

ISBN 978 0 85733 230 1 £21.99RRP



0 2 1 9 9

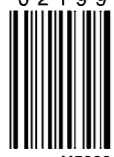

H5230

Haynes Publishing

Sparkford, Yeovil, Somerset BA22 7JJ, UK

Tel: 01963 442030 • Fax: 01963 440001

Int. tel: +44 1963 442030 • Int. fax: +44 1963 440001

E-mail: sales@haynes.co.uk • Website: www.haynes.co.uk

